

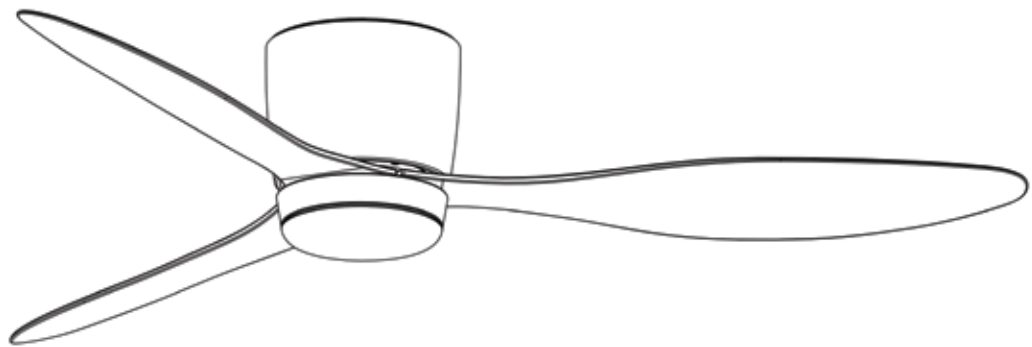

Item/Model Number: 88314WTMW / 88314WTSN / 88314WTPC
Aeries 52" 3-Blade Fan w LED Light Kit



Lamping | Ampoule: 1 x PCB In Tergared LED 18W

Please consult a qualified electrician prior to install
Veuillez consulter un électricien qualifié pour suspendre le luminaire et le câblage.

GENERAL 120V INSTRUCTIONS

English Before Getting Started	Français Avant de Commencer	Español Antes de Comenzar
Read the instructions carefully prior to assembling the product.	Lire attentivement les instructions avant d'assembler le produit.	Lea atentamente las instrucciones antes de ensamblar el producto.
When you open the package with a sharp tool like a box knife, be careful not to damage the components inside.	Lorsque vous ouvrez le paquet avec un outil pointu comme un couteau de coupe, veillez à ne pas endommager les composants à l'intérieur.	Cuando abra el paquete con una herramienta afilada como un cuchillo de corte, tenga cuidado de no dañar los componentes dentro.
Carefully remove all packaging materials and retain for future use.	Retirez soigneusement tous les matériaux d'emballage et conservez-les pour un usage ultérieur.	Retire con cuidado todos los materiales de embalaje y consérvelos para usarlos en el futuro.
Keep all hardware parts and packaging out of reach of children.	Conservez toutes les pièces matérielles et les emballages hors de portée des petits enfants.	Mantenga todas las piezas y embalajes de hardware fuera del alcance de los niños pequeños.
Choose a clean, level, spacious assembly area. Avoid hard surfaces that may damage the product.	Choisissez une zone d'assemblage propre, de niveau et spacieuse. Évitez les surfaces dures qui pourraient endommager le produit.	Elija una zona de ensamblaje limpia, nivelada y espaciosa. Evite superficies duras que puedan dañar el producto.
Ensure that you have all required contents for complete assembly.	Assurez-vous que vous avez tous les contenus requis pour l'assemblage complet.	Asegúrese de que tiene todos los contenidos necesarios para el ensamblaje completo.
Take care when lifting. Assemble the product in close proximity to where you intend to install it.	Prenez soin de soulever. Assemblez le produit à proximité de l'endroit où vous comptez positionner l'élément.	Tenga cuidado al levantar. Ensamble el producto cerca de donde tiene la intención de posicionar el artículo.
Do not over tighten the screws and bolts as this may damage the threads.	Ne serrez pas trop les vis et les boulons car cela pourrait endommager les filets.	No apriete excesivamente los tornillos y pernos, ya que esto puede dañar los hilos.
Do not let children play with this product.	Ne laissez pas les enfants jouer avec ce produit.	No permita que los niños jueguen con este producto.
Risk of suffocation! Keep packaging materials away from children.	Risque asphyxie! Tenez tous les matériaux emballage à l'écart des enfants	Riesgo de sofocación! Mantenga los materiales de embalaje lejos de los niños.
Lamp Care Instructions	Entretien de la Lampe	Instrucciones de Lámparas
Carefully read through the instruction sheet before assembly and using the product.	Avant de procéder à l'assemblage et à l'utilisation de la lampe, lisez attentivement le mode d'emploi.	Lea cuidadosamente la hoja de instrucciones (si fue proporcionada) antes de armar y utilizar la lámpara.
Caution there is a risk of shock! Disconnect from power source before assembling or cleaning.	Pour éviter tout risque d'électrocution, débranchez la lampe de la prise électrique avant de procéder à l'assemblage ou au nettoyage de la lampe.	Peligro por descarga eléctrica. Desconecte la lámpara de la fuente de electricidad antes de armarla o limpiarla.
Switch off, unplug and allow bulb to cool before replacing bulb or cleaning.	Avant de remplacer ou de nettoyer l'ampoule, éteignez et débranchez la lampe.	Apáguela, desenchúfela y deje que la bombilla se enfríe antes de reemplazarla o limpiarla.
Only use the recommended bulb type and do not exceed the maximum wattage as it could cause fire.	Afin d'éviter tout risque de feu, utilisez le type et la puissance d'ampoule recommandés.	Solo utilice el tipo de bombilla recomendado y no exceda la potencia eléctrica máxima ya que puede causar un incendio.
Check the product cord to be sure is free torn or frayed.	Ne branchez pas la lampe si son cordon d'alimentation est déchiré ou effiloché	No conecte la lámpara si el cable eléctrico está dañado o deshilachado.
Cleaning & Maintenance	Nettoyage et Maintenance	Limpieza y Mantenimiento
On polished finishes, often using talc powder can reduce the appearance of fingerprints and other smudges.	Sur les finitions polies, souvent en utilisant la poudre de talc réduit l'apparence des empreintes digitales et d'autres taches.	En acabados pulidos, a menudo usando polvo de talco reduce la aparición de huellas dactilares y otras manchas.
For respective shade surfaces, use the appropriate cleansers, i.e. glass cleaner, stone polish, & wood polish.	Pour les surfaces d'ombrage respectives, utilisez les nettoyants appropriés, c'est-à-dire le nettoyant pour vitres, vernis à pierre et le vernis à bois.	Para las respectivas superficies de sombra, utilice los limpiadores apropiados, es decir, limpiador de vidrio, esmalte acrílico y pulido de madera.
Clean with soft cloth and a mild detergent. Do not use abrasive or harsh cleaners.	Nettoyer avec un chiffon doux et un détergent doux. N'utilisez pas de nettoyant abrasif.	Utilice un trapo limpio, suave y seco que no raye ni manche la superficie cuando quite el polvo.
Periodically (every 90-180 days) make sure that the screws are fully tightened.	Périodiquement (tous les 90-180 jours), assurez-vous que les vis sont bien serrées.	Periódicamente (cada 90-180 días) asegúrese de que los tornillos estén bien apretados.
Prolonged exposure to heat sources may cause glazing, melting and scorching, or even cause color to fade.	Si le tissu subit une exposition prolongée aux sources de chaleur, il pourrait commencer à reluire, à roussir, à s'estomper ou même à se décolorer.	La exposición prolongada a las fuentes de calor causa cristalización, derretimiento, quemadura y decoloración del tapizado.

SAFETY INFORMATION

1. To reduce the risk of electric shock, ensure the electricity has been turned off at the circuit breaker or fuse box before you begin.

2. All wiring must be in accordance with the National Electrical Code ANSI/NFPA 70-1999 and local electrical codes. Electrical installation should be performed by a qualified licensed electrician.

3. The outlet box and support structure must be securely mounted and capable of reliably supporting 35 lbs. (15.9kg). Use only UL Listed outlet boxes marked "Acceptable for Fan Support of 35 lbs.(15.9kg) or less."

4. The fan must be mounted with a minimum of 7 ft. (2m) clearance from the trailing edge of the blades to the floor.

5. Do not place objects in the path of the blades.

6. Electrical diagrams are for reference only. Light kits that are not packed with the fan must be UL-listed and marked suitable for use with the model fan you are installing. Switches must be UL General Use Switches. Refer to the instructions packaged with the light kits and switches for proper assembly.

7. After making electrical connections, spliced conductors should be turned upward and pushed carefully up into the outlet box. The wires should be spread apart with the grounded conductor and the equipment-grounding conductor on the side of the outlet box.

before installation.

8. All setscrews must be checked and retightened where necessary



WARNING:To reduce the risk of personal injury, do not bend the blade brackets (also referred to as flanges) during assembly or after installation. Do not insert objects in the path of the blades.



WARNING:Remove the rubber motor stops on the bottom of the fan before installing the blades or testing the motor.



WARNING:To reduce the risk of fire or electric shock, do not use this fan with any solid-state speed control device.



WARNING:To avoid possible electrical shock, turn the electricity off at the main fuse box before wiring. If you feel you do not have enough electrical wiring knowledge or experience, contact a licensed electrician.



WARNING:Electrical diagrams are for reference only. Optional use of any light kit shall be UL-listed and marked suitable for use with this fan.



WARNING:To reduce the risk of fire, electric shock, or personal injury, mount to outlet box marked "Acceptable for fan Support of 35 lbs.(15.9kg) or less," and use the screws provided with the outlet box.



CAUTION:To reduce the risk of personal injury, use only the screws provided with the outlet box.



CAUTION:To avoid personal injury or damage to the fan and other items, use caution when working around or cleaning the fan.



NOTE: These are approximate measures. They do not include the Amps and Wsttage used by the light kit.

TOOLS REQUIRED



Phillips screwdriver



Flat blade screwdriver



Adjustable wrench



Electrical tape



Wire cutter



Step Ladder

PRE-INSTALLATION (CONTINUED)

HARDWARE INCLUDED



NOTE: Hardware not shown to actual size.

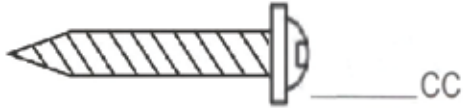
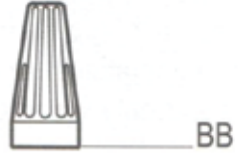

Part	Description	Quantity
AA	Blade attachment screws	7
BB	Wire connecting nut	3
CC	Wood screw	4
UU	Mounting screws	2

PRE-INSTALLATION (CONTINUED)

PACKAGE CONTENTS

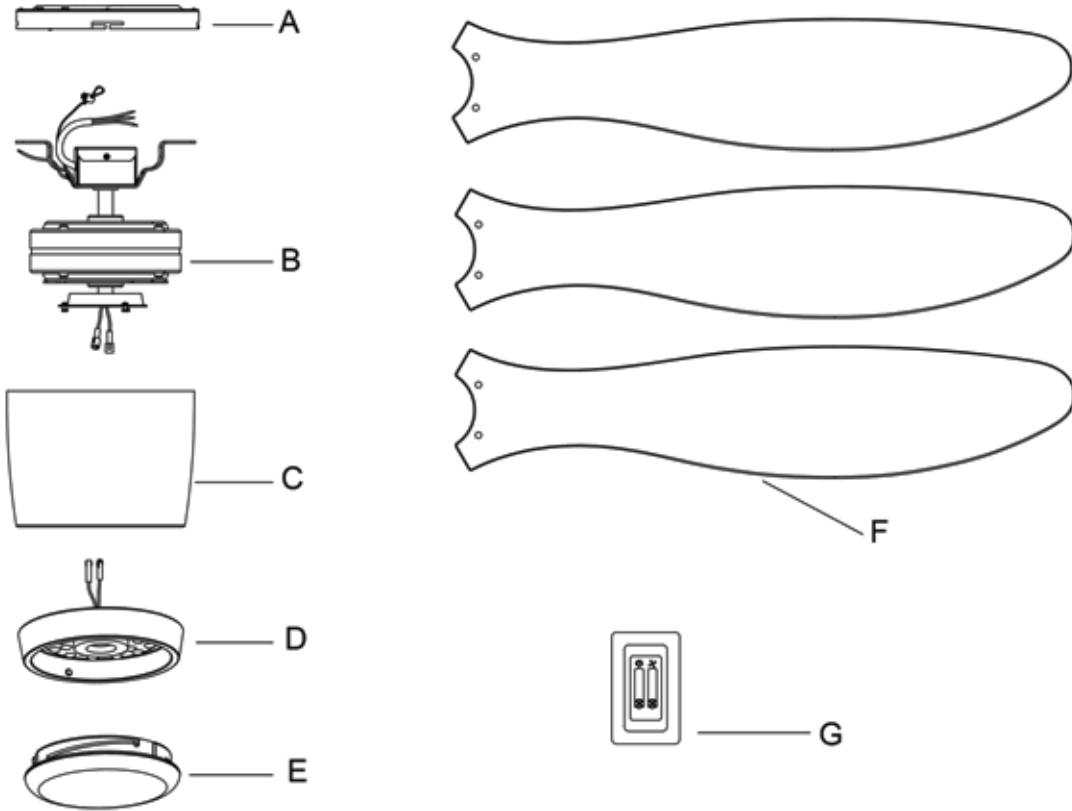

Part	Description	Quantity
A	Slide-in mounting bracket tray	1
B	Fan-motor assembly	1
C	Fan motor enclosure	1
D	LED Light pan	1
E	Lampshade	1
F	Blade	3
G	Wall control	1

INSTALLATION

MOUNTING OPTIONS



WARNING: To reduce the risk of fire, electric shock, or personal injury, mount to outlet box marked "Acceptable for fan Support of 35 lbs.(15.9kg) or less," and use the screws provided with the outlet box. An outlet box commonly used for the support of lighting fixtures may not be acceptable for fan support and may need to be replaced. If in doubt, consult a qualified electrician.

If your ceiling fan does not have an existing UL-listed mounting box, then install one using the following instructions:

- Disconnect the power by removing the fuses or turning off the circuit breakers.
- Secure the outlet box directly to the building structure. Use the appropriate fasteners and materials. The outlet box and support structure must be securely mounted and capable of reliably supporting 35 lbs. (15.9kg). Use only UL Listed outlet boxes marked "Acceptable for Fan Support of 35 lbs. (15.9kg) or less." . Do not use a plastic outlet box.

The illustrations below show three different ways to mount the outlet box.

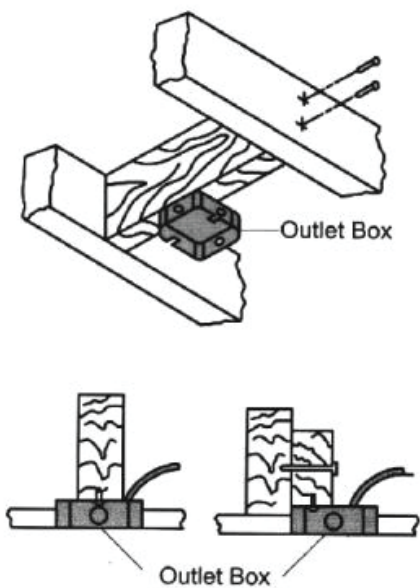

NOTE: You may need a longer downrod to maintain proper blade clearance when installing on a steep, sloped ceiling. The maximum angle allowable is 30° away from horizontal.

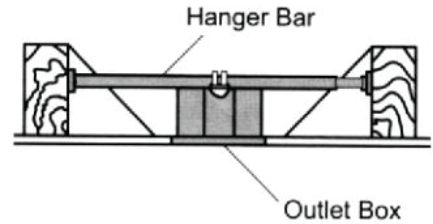

If the canopy touches the downrod, then remove the decorative canopy bottom cover, and turn the canopy 180° before attaching the canopy to the mounting plate.

To hang your fan where there is an existing fixture but no ceiling joist, you may need an installation hanger bar as shown above.

ASSEMBLY - HANGING THE FAN

1 Attaching the fan to the electrical box



WARNING: To reduce the risk of fire, electric shock or personal injury, mount to outlet box marked "Acceptable for fan support of 35 lbs. (15.9kg) or less", and use screws provided with the outlet box.

- Pass the 120-Volt supply wires through the center hole in the mounting bracket (A).
- Install the ceiling mounting bracket on the outlet box by sliding the mounting bracket (A) over the two screws (UU) provided with the outlet box. If necessary, use leveling washers (not included) between the mounting bracket (A) and the outlet box. Note that the flat side of the mounting bracket (A) is toward the outlet box. When using close-to-ceiling mounting, it is important that the mounting bracket be level.
- Securely tighten the two mounting screws (UU).

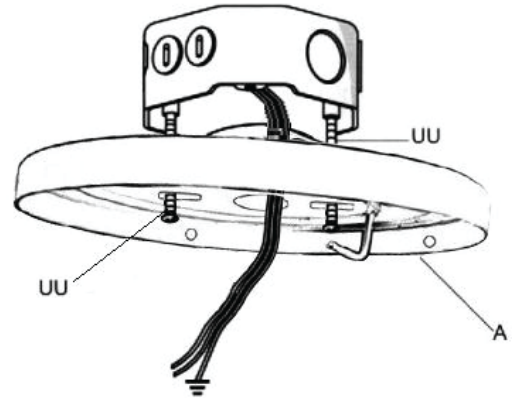

ASSEMBLY - HANGING THE FAN

2 Hanging the fan

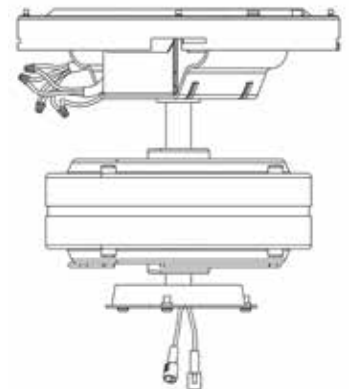
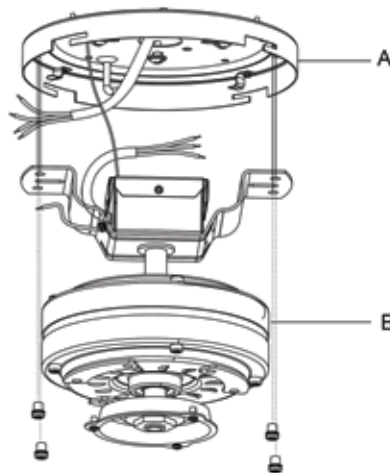
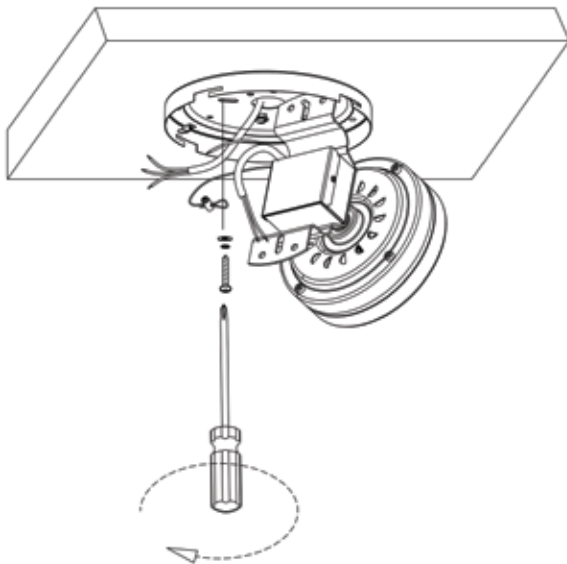

- Tighten the safety wire clamp. Place ring of safety wire through the expansion bolt or self tapping screw and fix it to the building structure.
- Carefully lift the fan-motor assembly (B) up to the Slide-in mounting bracket tray (A).
- Install the fan-motor assembly (B) using the 4 mounting screws on the slide-in mounting bracket tray(A)

ASSEMBLY – HANGING THE FAN (CONTINUED)

3 Making the electrical connections



WARNING: Each wire nut supplied with this fan is designed to accept up to one 12-gauge house wire and two wires from the fan. If you have larger than 12-gauge house wiring or more than one house wire to connect to the fan wiring consult an electrician for the proper size wire nuts to use.



IMPORTANT: Use the plastic wire connectors (BB) supplied with your fan. Secure the connectors with electrical tape and ensure there are no loose strands or connections.

- The fan comes with 18 in. lead wires for use with assembly. you can cut the lead wires to your desired length. This will make extra room in the fan-motor assembly (B), if you do not wish to cut the wires, you will need to neatly wrap them.
- Connect the fan motor green wires to the household green or bare wire using a wire connecting nut (BB).
- Connect the fan motor white wire to the household white wire using a wire connecting nut (BB).
- Connect the fan motor black and blue wires to the household black wire using a wire connecting nut (BB).
- How to wire and operate wall control. Refer to page 10 later.

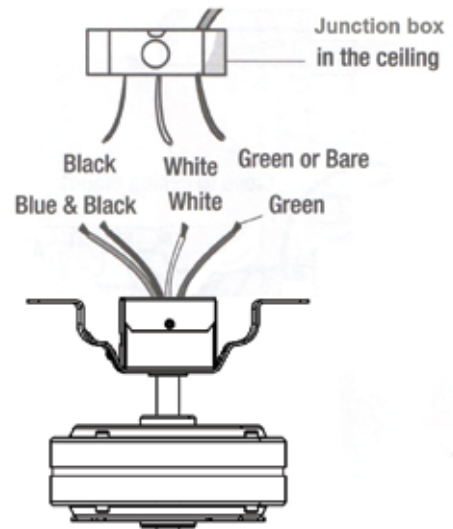

ASSEMBLY – HANGING THE FAN (CONTINUED)

4 Mounting the Fan motor enclosure



WARNING: The lock slot for mounting the support tray is used only for auxiliary installation. Do not leave the fan assembly unattended until it is engaged and securely tightened.

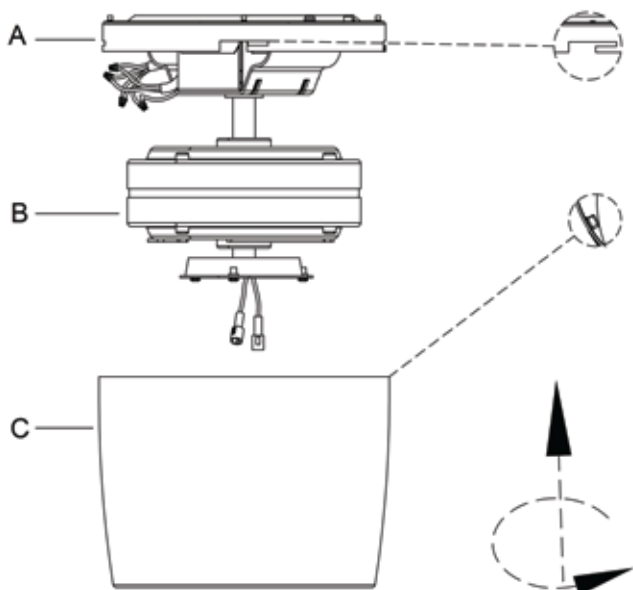

- Carefully fit the Fan motor enclosure (C) into the motor assembly (B) and align the locking slots of the Fan motor enclosure (C) with the four locking slots on the mounting support tray (A). Push upward into the locking slot and turn clockwise to lock into place.



ASSEMBLY - ATTACHING THE FAN BLADES (CONTINUED)

5 Fastening the blade to the motor

- Fasten the blade (F) to the fan-motor assembly (B) by the blade screws (AA).
- Repeat this step for the remaining blade .

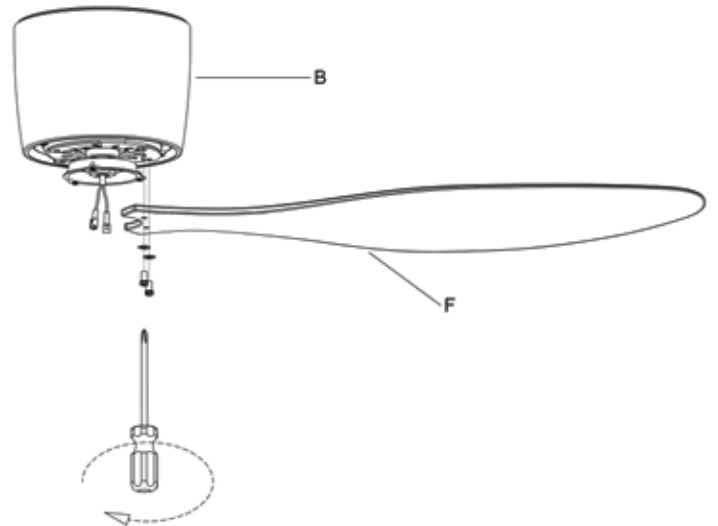

ASSEMBLY - ATTACHING THE LIGHTS

Assembly - Attaching the Lights



CAUTION: To reduce the risk of electric shock, disconnect the electrical supply circuit to the fan before installing the light fixture.

6 Attaching the LED light kit

- Remove the three screws (VV) from the fan - motor (B).
- Connect white wire from fan to white wire from LED light kit and then connect blue wire from fan to black wire from LED light kit.(SS)
- Attach light pan (D) onto the plate on motor (B), aligning the keyhole slots on the light plate with the preassembled screws on the plate. Reinstall the screw removed in . Tighten all screws securely.

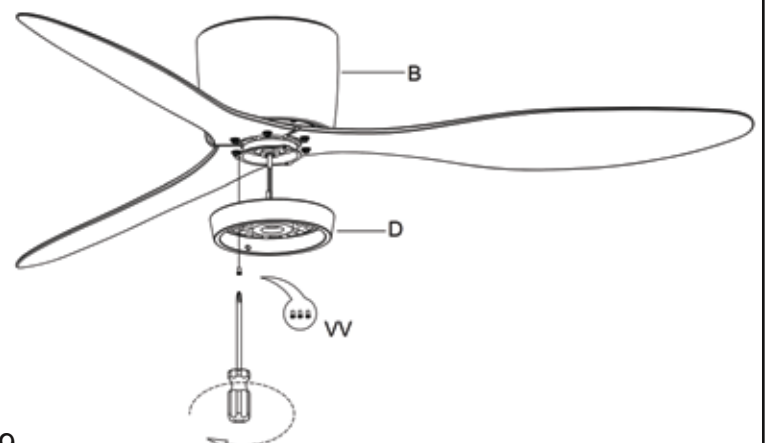
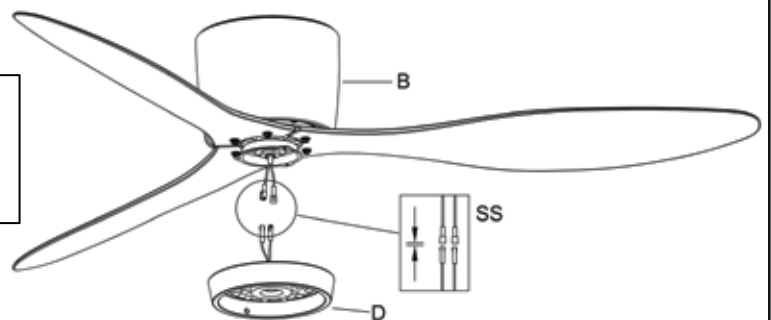

ASSEMBLY – ATTACHING THE LIGHT PAN BOWL

7 Attaching the light kit pan bowl



WARNING: Do not overtighten when installing the lampshade into the light kit assembly. Allow the lampshade shade to cool completely before removing.

- Place the lampshade (E) into the light kit assembly (D) , Turn the lampshade (E) clockwise until it stops.

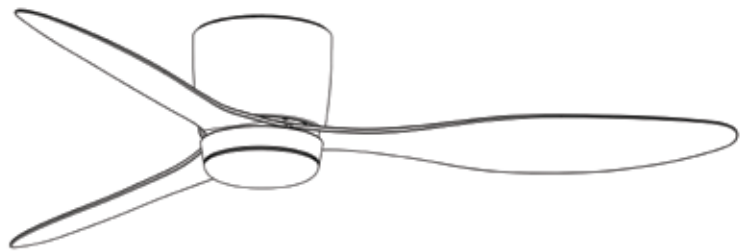
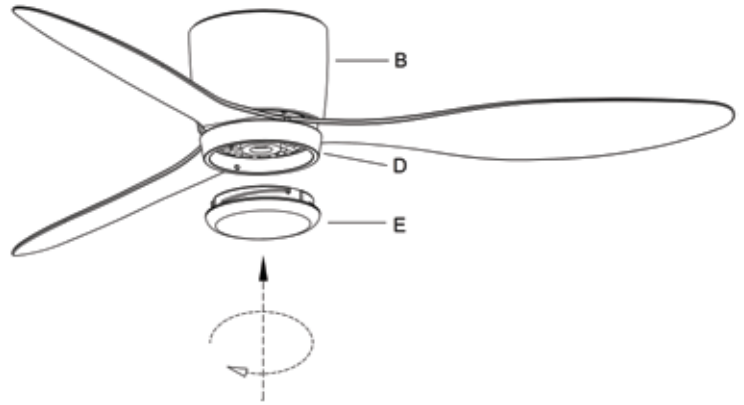

DUAL-SLIDE CEILING FAN - WALL MOUNTED CONTROL

1. IMPORTANT POINTS TO REMEMBER:

Read carefully before attempting to install this electrical device and retain the instruction for future reference.

1. Please note that all fixed wiring appliances should be installed by a qualified electrician.
2. To avoid possible electrical shock, be sure electricity is turned off at the main fuse box or circuit breaker panel before wiring.
3. Do not mount wall control near heat producing equipment.
4. Use of this control with some ceiling fans could result in fire, shock and serious personal injury. Use this speed control only with capacitor speed controlled ceiling fans.
5. Make certain no bare wires are exposed outside the connectors.
6. This unit is to be used for the control of ceiling fans at AC120V 60Hz power supply only.

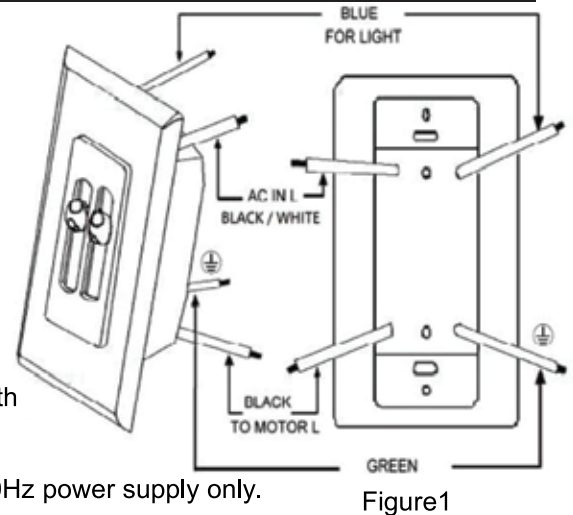

Figure 1

2. INSTALLATION INTRUCTIONS

Disconnect the power and remove the existing wall plate and switch

1. Set all knobs on the dual slide wall-mounted control in the OFF position.
2. Installation of this control requires that a three-conductor cable with ground wire be run between the control wall box and the ceiling fan outlet box. (Figure 1)
3. Make wire connections and secure with wire nuts supplied refer to figure 2.

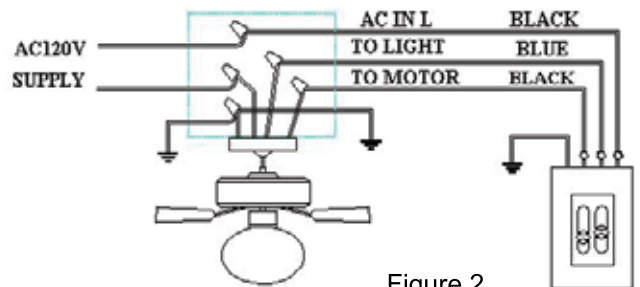

Figure 2

- *Connect black wire from A.C. power supply to black wire from the wall-mounted control.
- *Connect black or red wire from the ceiling fan to black wire from the wall-mounted control.
- *Connect blue wire from the ceiling fan to blue wire the wall-mounted control.

4. Secure the wall-mounted control to the outlet box with two screws provided. (Figure 3)
5. Secure the face plate over the wall control with two screws provided.

NOTE

If your ceiling fan would be used with the original pull chain switch, please always have the fan switch set to high speed and the light switch set to on position before using the wall control. To avoid accidental pull chain use, shorten chain by cutting it 1" below switch body.

FUNCTION:

- Fan switch:
- : POWER OFF
 - L. LOW SPEED
 - LOW SPEED
 - MEDIUM SPEED
 - HIGH SPEED

Light Switch:
 -: POWER OFF
 When you push the knob upward slowly, the lightness of light will turn brighter and brighter.

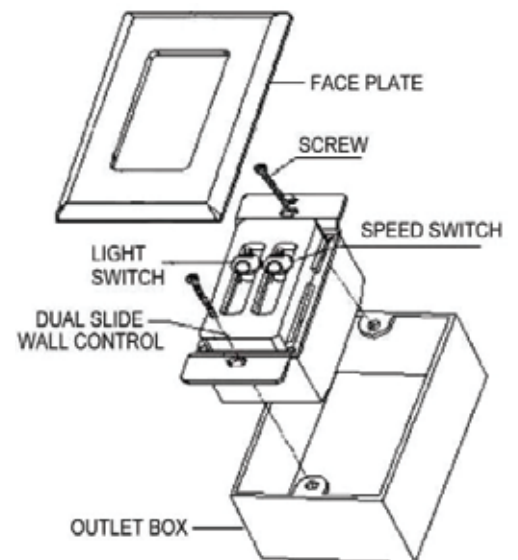

Figure 3

CARE AND CLEANING



WARNING: Make sure the power is off before cleaning your fan.

- Because of the fan's natural movement, some connections may become loose. Check the support connections, brackets, and blade attachments twice a year. Make sure they are secure. It is not necessary to remove the fan from the ceiling.
- Clean your fan periodically to help maintain its new appearance over the years. Do not use water when cleaning, as this could damage the motor, or the wood, or possibly cause an electrical shock. Use only a soft brush or lint-free cloth to avoid scratching the finish. The plating is sealed with a lacquer to minimize discoloration or tarnishing.
- You can apply a light coat of furniture polish to the wood for additional protection and enhanced beauty. Cover small scratches with a light application of shoe polish.
- You do not need to oil your fan. The motor has permanently-lubricated sealed ball bearings.

TROUBLE SHOOTING

Problem	Solution
The fan will not start.	<ul style="list-style-type: none"> <input type="checkbox"/> Check the main and branch circuit fuses or breakers. <input type="checkbox"/> Check the line wire connections to the fan and switch wire connections in the switch housing.
The fan is noisy.	<ul style="list-style-type: none"> <input type="checkbox"/> Ensure all motor housing screws are snug. <input type="checkbox"/> Ensure the screws that attach the blade bracket to the motor hub are tight. <input type="checkbox"/> Ensure the wire nut connections are not rattling against each other or the interior wall of the switch housing. <input type="checkbox"/> Allow a 24-hour "breaking in" period. Most noises associated with a new fan disappear during this time. <input type="checkbox"/> If you are using the Ceiling Fan light kit, ensure the screws securing the glassware are tight. Check that the light bulbs are also secure. <input type="checkbox"/> Ensure the canopy is a short distance from the ceiling. It should not touch the ceiling. <input type="checkbox"/> Ensure your outlet box is secure and rubber isolator pads were used between the mounting plate and outlet box.
The fan wobbles.	<ul style="list-style-type: none"> <input type="checkbox"/> Check that all blade and blade arm screws are secure. <input type="checkbox"/> Most fan wobble problems are caused when blade levels are unequal. Check this level by selecting a point on the ceiling above the tip of one of the blades. Measure from a point on the center of the blade to the point on the ceiling. Rotate the fan until the next blade is positioned for measurement, and measure from the same point on each blade to the ceiling. Repeat for each blade. Any measurement deviation should be within 1/8 in. Run the fan for ten minutes. If the fan continues to wobble please contact Customer Service and a balancing kit will be sent to you at no charge.